

AGRI WELD

Operator Manual

120F Forward Tip

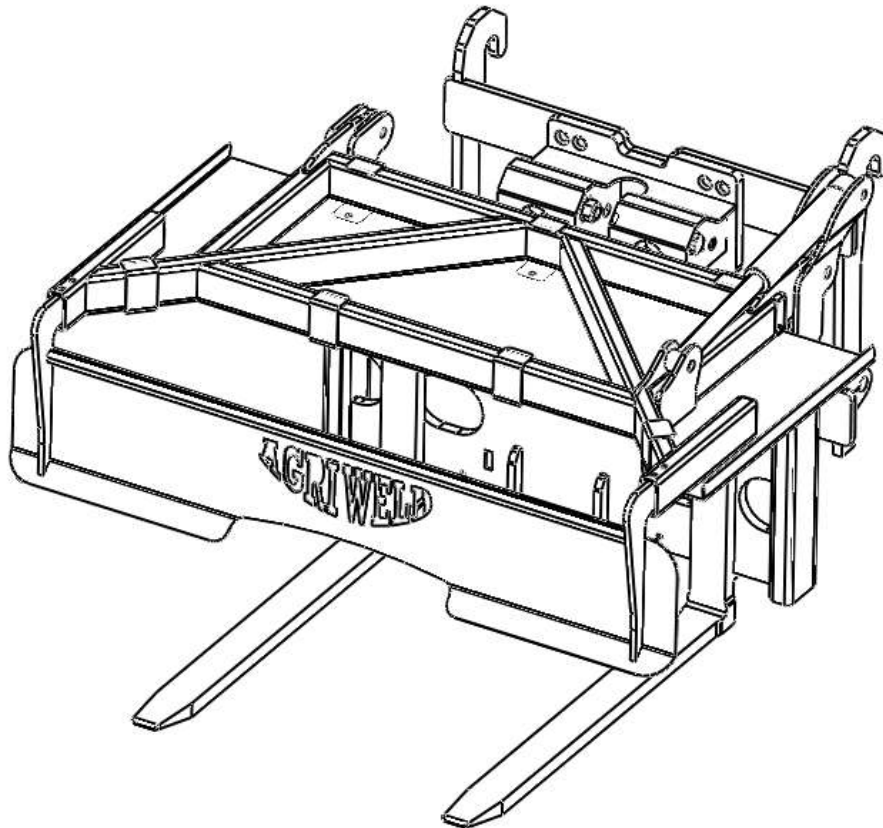

www.agriweld.co.uk

The Workshops
Main Street
Garton-on-the-Wolds
Driffield, YO25 3ET
Tel: 01377 259140
Fax: 01377 259141

Email: sales@agriweld.co.uk

Contents Page

Page 3	User Information & Getting Started
Page 4	Safety, Dangers, operating errors and exemption from liability, Qualification & Training,
Page 5	General Safety
Page 6	Important Safety Instructions
Page 7	Connection & Attachment to the Telehandler/Loader & Attachment
Page 8	Adjustment
Page 9-10	Rules of conduct for Operation and Operation
Page 11-12	Maintenance
Page 13	Acquiring spare parts and Disposing of replaced parts
Page 14	Full assembly
Page 15	Back plate
Page 16	Carriage
Page 17	Main shaft assembly
Page 18	Top arm
Page 19	Forklift brackets
Page 20	Rams and pallet forks
Page 21	Stickers
Page 22	Electric spiral cable
Page 23	Warranty
Page 24	C E Declaration of Conformity

User information

Before using your 120F Box Rotator for the first time it is IMPORTANT that all operators make themselves familiar with the unit and must read this OPERATOR MANUAL and SAFETY INSTRUCTIONS attentively.

Getting started

The 120F Box Rotator will be fitted and delivered with the correct Bolt-On brackets/carriage blocks to suit the fork-lift/loader it is intended to fit. SEE BOLT ON BRACKETING INSTRUCTIONS AND BOLT SPECIFICATIONS SECTION FOR FULL INFORMATION. If for any reason the fittings are lost or damaged, or if the bracketing is removed for any reason, please refer back to this information in order to refit the brackets and/or replace any lost fittings with the correct specification.

The 120F Box Rotator will also be fitted with the correctly swaged hydraulic pipes and fittings applicable to your forklift/loader and as per your request. If these pipes are damaged they must be replaced immediately with NEW pipes and fittings. **DO NOT ATTEMPT TO REPAIR HYDRAULIC PIPES OR ALLOW ANY ONE ELSE TO REPAIR THEM.**

Any replacements can be ordered from us and sent to you overnight if required.

The 120F Box Rotator is a low maintenance unit, and requires little mechanical attention as such, other than **greasing the main pivots, and hydraulic ram/rod ends at the greasing points located and visible at these areas and by following a general basic care routine.**

Your **120F Box Rotator weighs 780kg** including bracketing and has a **max loading of 2.0 tonnes.**

NOTE: During use, please be aware of increased weight due to shock loading. This includes performing manoeuvres such as driving down a rough field, at some speed, with a full box. The resulting bouncing effect is known as shock loading and the weights can be significantly magnified to the point of overload.

The 120F Box rotator is not to be used for any other purpose than for which it is intended - that is the lifting and rotating of one box containing free flowing product at a time. **It is not to be used as a fork lift.** Damage to the unit resulting from overload will not be covered under a warranty or liability claim.

The specifications, descriptions and illustrations in this manual are accurate at the time of publication but may be subject to change.



Safety

All operators of the 120F and forklift/loader must hold the appropriate forklift licence or certificate of competence to do so.

All operators must be familiar with the 120F Operator Manual and forklift/loader operations prior to use. If safety instructions are not observed and complied with it can lead to the risk of injury to the operator and others as well as damage to the machine, property and the environment. Non-compliance to the safety instructions can lead to claims for damages/injury becoming invalid.

Dangers, operating errors and exemption from liability

1. No responsibility will be accepted for possible dangers arising from operations complying with the designated use.
2. Damage to agricultural produce particularly vulnerable to damage during processing cannot be entirely ruled out. Weather conditions, the quality of the produce and many other circumstances beyond our or the operator's control have an influence on the vulnerability to damage of the produce being processed. For example, when processing potatoes the submerged weight of the potatoes, the manuring (nitrogen content) of the potatoes, the degree of maturity (firmness of the skin) of the potatoes, the temperatures during processing and many other circumstances can have an influence on the vulnerability to damage. These examples do not claim to be exhaustive.
3. To avoid damage to agricultural produce the user must adapt the machine to the respective operating conditions. The results produced by the machine must be constantly monitored and checked.
4. Agriweld shall not be liable for any damage to agricultural produce and other items, which occurs as a result of normal operating, adjustments errors or other incorrect usage.
5. Agriweld accepts no liability for any damage caused as a result of operations not complying with the designated use of the machine. This also applies to damage to agricultural produce caused by certain external influences, which cannot be avoided with the current state of the art.

Qualification & training

Only personnel with the appropriate forklift/loader licence are authorised to use this machine.

Statutory minimum age limits must be observed and reliable personnel only should perform maintenance/work on this machine.



Persons undergoing training or instruction or taking part in a general training course should only use this machine under direct supervision of an experienced and trained person.

Agriweld shall not be responsible for any damage/injury caused by the use of parts/repairs not supplied and/or approved by Agriweld.

General safety

Any warning signs/instructions on the machine provide important information and must be observed.

Ensure that you are familiar with the machine before starting work.

Check round the machine for any noticeable damage, or missing parts before starting work.

It is advisable that the operator does not wear jewellery and loose-fitting clothing to avoid the risk of snagging and trapping.

Ensure that you are working in an area clear of obstructions and watch out for wandering individuals (particularly children!).

Important safety instructions

Take extra care when attaching the 120F to the forklift/loader to ensure that it is attached correctly via the bracketing and hydraulic fittings. Ensure that the forklift/loader and its hydraulic system are in full working order.

Never allow any person to stand between the forklift/loader and the 120F during connection or at any time.

Never exceed the permissible weight of the box and its contents for handling.

Ensure that the top arm is set in accordance with the OPERATOR INSTRUCTIONS in relation to the sizes of box being handled at the time and NOTE that this may need adjustment for different sized boxes.

Take into account the protrusion of the machines pallet forks (a further 1200mm from the carriage of the unit) when manoeuvring around and take particular care when approaching junctions and negotiating corners.

The driving characteristics of the forklift/loader are influenced and altered by the attachment of mounted machines and it is important to ensure adequate steering and braking ability as required.

Never allow any person to sit or ride on the 120F and forklift/loader at any time.

Never perform any adjustments to the 120F whilst mounted, unless the forklift/loader is stopped, turned off and the 120F is resting on the ground where possible.

Ensure that the forklift/loader cannot roll away by use of a park brake or wheel chocks.

Keep clear of unit discharge to avoid being hit by stray produce.

NEVER ALLOW ANY PERSON TO STAND OR WORK BENEATH A SUSPENDED LOAD!

Connection to the forklift/loader

The 120F will be delivered already fitted with the correct bolt-on bracketing, hydraulic fittings and hydraulic hose to fit your Telehandler.

If for any reason the fittings are lost or damaged they must be replaced with the following specification of fitting;

QUICK-HITCH brackets require the following fittings;

8 X M20 X 50mm counter sunk socket head setscrew BZP - high tensile 10.9

8 X M20 high tensile grade 8.8 Nylock nuts

8 X M20 good quality washers (fitted nut side.)

For your own safety and the safety of others, always use the correct fittings to attach bolt-on bracketing to the rear of the unit. Always place the unit on the ground and turn off the forklift/loader before attempting any changes.

Attachment

Stand the 120F up the correct way, in an area free from obstruction to allow you to drive the forklift/loader towards the bracketing.

For Quick Hitch bracketing, connect as you would with any other attachment and the type of bracketing fitted to the box rotator.

The 120F is not designed to fit standard yard trucks, only telehandlers/loaders with a 3 tonne capacity or over.

Attach the hydraulic hoses via the pipes and fittings supplied on the 120F to fit your loader whilst it is TURNED OFF.

NOTE: A 12 volt, spiral electric cable is required to operate the function of the top grab (not provided as standard). Please ensure that one is fitted and connected to both the rotator and your loader as per the **SPRIAL CABLE INSTRUCTION SHEET AT THE BACK OF THIS OPERATOR MANUAL.**

If your machine is being exported out of the UK, for safety purposes we cannot run any hydraulic oil through the machine for shipping, please be aware that you will need to plug your hydraulic couplings in to the forklift/loader and run the machine through with hydraulic oil for operation.

YOU ARE NOW READY FOR OPERATION.



Adjustment

The 120F requires immediate adjustment of the top hydraulic clamping arm and pallet forks in relation to the size of boxes you will be handling. This will require repeating when you change to different size boxes. Set the pallet forks using the latches located on the top of the fork to the maximum width your boxes can take for stability.

For ease of adjusting the top grab (50mm or so higher than the height of the box to allow for driving in lowering the arm so that it does not crush the top of the box).

1. Rotate the unit 90 degrees on the forklift so the top arms are parallel to the ground. This means that the operator will not have to manually lift the arms vertically.
2. Adjust one side at a time by removing the pin and pulling out the arm to desired height. Repeat the other side. The arm is adjusted simply via a pin system at 50mm increments located on the left and right side of the carriage. Ensure the pins are fully located and the lynch pin is replaced to prevent the pin working loose.

The top arm raises to 90 degrees allowing easy access in and out of the box. It requires a separate hydraulic or electric supply to operate.

The pallet forks can be seen below the rotators carriage and back plate to guide you into the box.

The adjustment range of the 120F arms/forks are as follows:

Top Arm (taken from top of pallet fork to underside of arm)

MINIMUM HEIGHT:	700mm	MAXIMUM HEIGHT:	1250mm
-----------------	-------	-----------------	--------

Box Depth (taken from front of pallet forks to back of logo guard)

MINIMUM DEPTH:	1015mm	MAXIMUM DEPTH:	1260mm
----------------	--------	----------------	--------

Pallet Forks (outside to outside)

MINIMUM WIDTH:	780mm	MAXIMUM WIDTH:	1080mm
----------------	-------	----------------	--------



Rules of Conduct for Operation

The following points must always be observed before the machine is started up and during operation:

- Never leave the machine unattended.
- Check the machine regularly for oil leakage. Replace defective components immediately.
- The user is responsible for damage to the produce caused by oil leakage.
- Check the machine for dirt accumulation and clean it on a regular basis.

Rules of conduct when handling the hydraulic system

DANGER

The hydraulic system is under high pressure!

Fluids escaping under high pressure can penetrate the skin and cause serious injuries! If such injuries occur, call a doctor immediately as otherwise there is a risk of serious infection!

Consequently: Work only on the hydraulic system when the hydraulic system is depressurized and the drive is switched off.

Note

All components of the machine are driven hydraulically. Replace defective hose connections immediately. The user is responsible for damage to the produce caused by oil leakage.

Operation

Once the 120F is attached to the Telehandler/loader correctly and adjusted for the correct box size and a 12 Volt, spiral electric cable is attached from the 120F to your loader (not provided as standard) you can begin operation.

The following step by step procedure will take you through the basic operation of the machine;

The 120F's pallet forks can be seen below the rotators carriage and back plate to guide you. The hydraulic top arm will lift fully to 90 degrees to allow easy access into the box.

Drive in to collect a full box until the rear of the box touches the 120F's carriage (as far back as it will sit).

Ensure that the 120F is not tilted forwards on the forklift/loader as the box could slide off.



Pick up the box, and lower the hydraulic top arm using the electric switch in the operators cab or by using the second hydraulic service. Tilt the rotator back slightly to keep the load against the carriage and drive to the desired tipping point.

Position the Telehandler/loader so that on rotating the box, the product will fall as required and begin forward rotation. The speed is pre-set before delivery and you do not need to worry about "feathering" the controls as the rotator will tip forwards at a steady speed without jarring. The removable lid on the hydraulic top arm will ensure that the load does not scatter and will assist in dropping the load as required.

Once the box is empty, rotate the box fully back. It will return to level at all times. Drop the box off where required. On leaving the box it is easier to slightly tilt the forklift carriage forwards to aid exit from the box.

If you decide not to empty the box fully, the 120F will return to level if required with a part full box.

Repeat the process.

**REMEMBER TO ADJUST THE BOX ROTATOR SIDE AND TOP ARMS FOR DIFFERENT BOX SIZES.
TOO MUCH SPACE BETWEEN THE BOX AND ARMS OF THE ROTATOR IS DANGEROUS AS
EXCESSIVE FREE MOVEMENT COULD RESULT IN LOSING THE BOX OFF.**



Maintenance

Regular maintenance is a prerequisite for good operational reliability. The following safety advice is to be observed before starting any maintenance, cleaning or repair work.

Trained personnel may only execute maintenance activities.

Inform operating personnel before beginning special operations and maintenance work! Delegate a supervisor!

If necessary, ensure that the maintenance area is adequately secured.

Use suitable tools and wear gloves when working on the machine!

Switch off the machine completely for maintenance and repair work and ensure that it is protected against inadvertent starting by:

- Locking the principal controls and removing the ignition key and/or
- Detaching the hydraulic supply.

Carry out maintenance and repair work only when the machine is positioned on stable and level ground and has been secured against involuntary movement and toppling.

To avoid the risk of accidents, individual parts and larger subassemblies being moved for replacement purposes should be carefully securely attached to lifting tackle. Use only suitable hoisting and lifting gear with adequate load capacity, which is in proper working condition. Never work or stand under suspended loads!

The securing of loads and the instruction of crane operators should only be entrusted to experienced persons. A signaller giving instructions must be within sight of the crane operator or must be provided with a radio link.

For carrying out overhead work, always use specially designed facilities or safe ladders/platforms. Never climb on the machine itself! Wear a safety harness when carrying out maintenance work at greater heights.

Clean the machine, especially connections and threaded unions, of any traces of oil, fuel or preservatives before carrying out maintenance/repairs! Never use aggressive detergents. Use lint-free cleaning cloths.

Before cleaning the machine with water or steam jets (high-pressure cleaners) or other cleaning agents, cover or tape all openings which – for safety and operational reasons – must be protected against ingress of water, steam or cleaning agents.

After cleaning, examine all fuel, lubricant and hydraulic oil lines for leaks, loose connections, scuffing marks and damage. Any defects found must be rectified without delay.

Always retighten any screwed connections that have been unscrewed during maintenance and repairs.

Any safety devices removed for setting-up, maintenance or repair purposes must be refitted and checked immediately upon completion of the maintenance and repair work and prior to operation.

We recommend greasing your box rotator using a good quality general purpose grease weekly whilst working under normal conditions, and twice weekly under extreme use and or very dry/dusty conditions.

Instructions

- Whilst connected to the Forklift/loader grease all parts (main pivot, hydraulic cylinders) using 3 pumps from the gun.
- Being aware of your own safety/safety of others, rotate the machine through its entire cycle and repeat the process.
- Rotate machine on forklift/loader back and forth several times to work the new grease in.
- You are now ready to use the machine again.

It is important to follow the recommended greasing routine to protect your 120F from damage and prolong the lifespan of its main operating parts.

Failure to carry out this maintenance may result in your warranty becoming invalid due to non-maintenance.

Acquiring spare parts

Please quote the details on the type plate(s) as well as the machine's serial no. on every order for spare parts or accessories, or enquiries of a technical nature.

The use of spare parts supplied by others shall only be permitted after consultation with the manufacturer. Original spare parts and accessories authorised by the manufacturer ensure safe and reliable operation. The use of other parts may invalidate the liability of the manufacturer for any consequences arising from such use.

Disposing of replaced parts

The following points should be observed before replacing or disposing of parts.

- Replaced parts, which still function, should be cleaned and stored in an orderly manner.
- Machine parts, which cannot be repaired should only be disposed of at appropriate collecting points or be collected by a scrap metal dealer.
- So-called "valuable" materials should be disposed of in a proper way, i.e. plastics, rubber, scrap metal, etc. should be recycled.
- Collect and dispose of old oil in accordance with the current regulations.

Full assembly

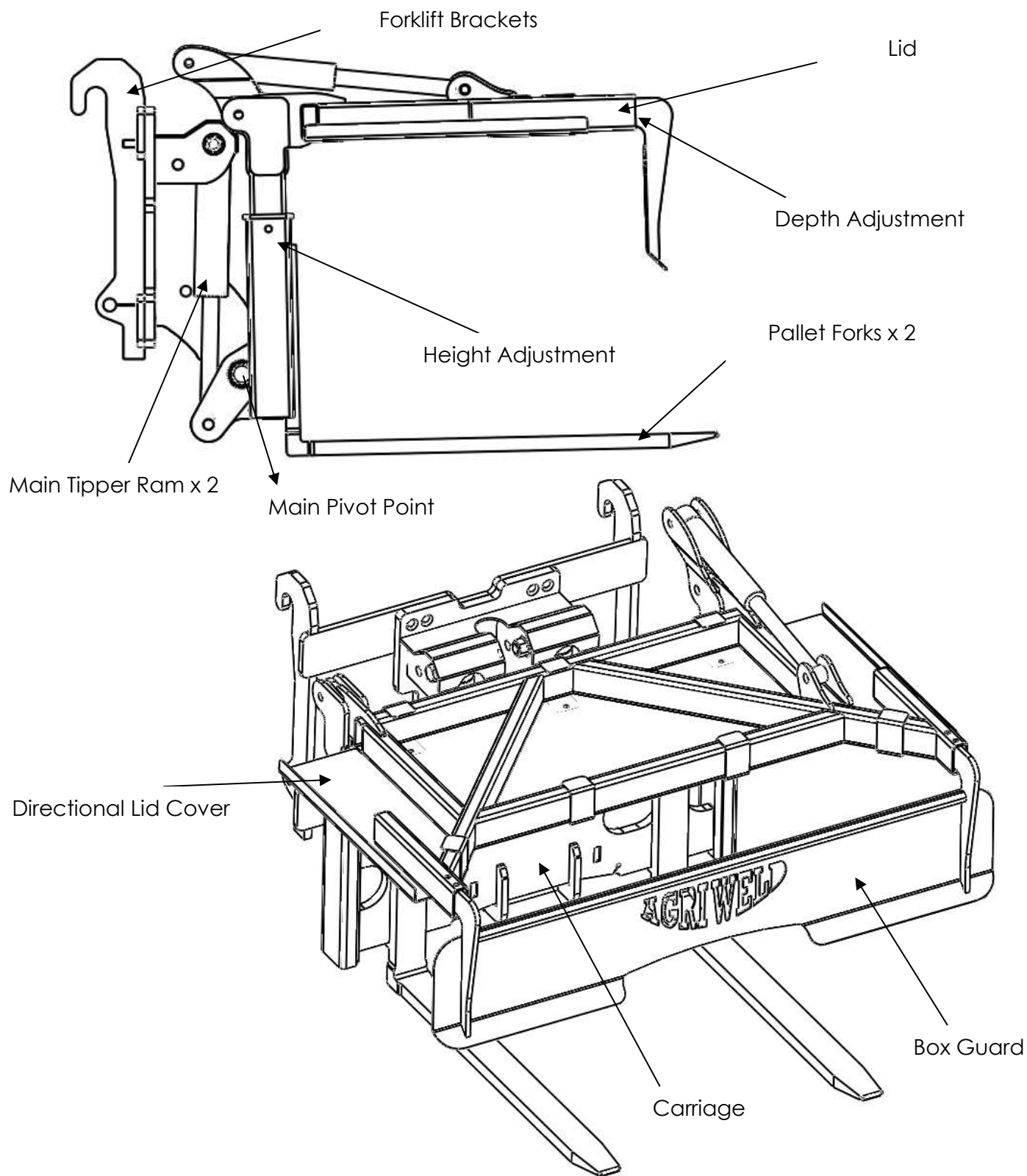

Back plate

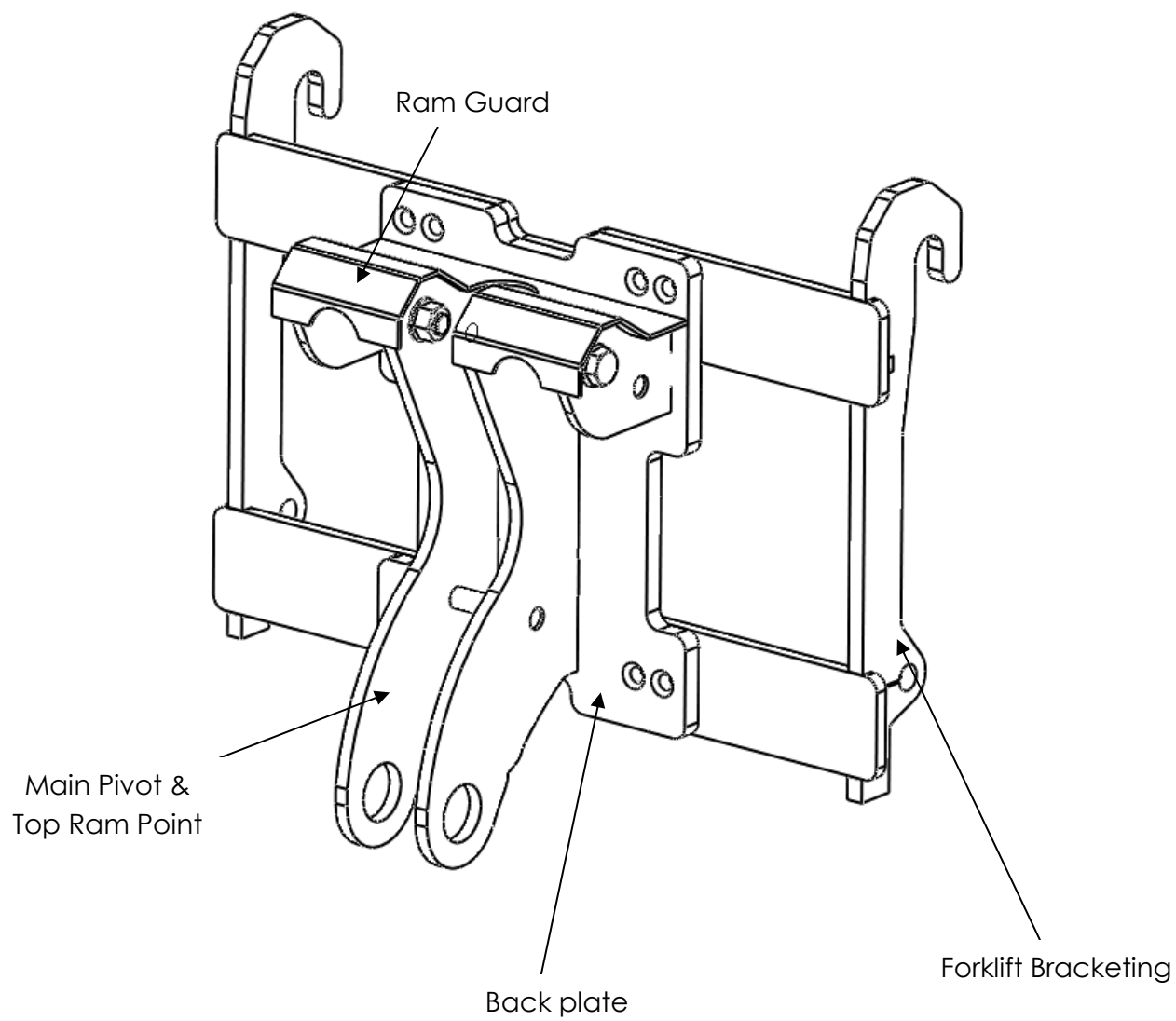

Carriage

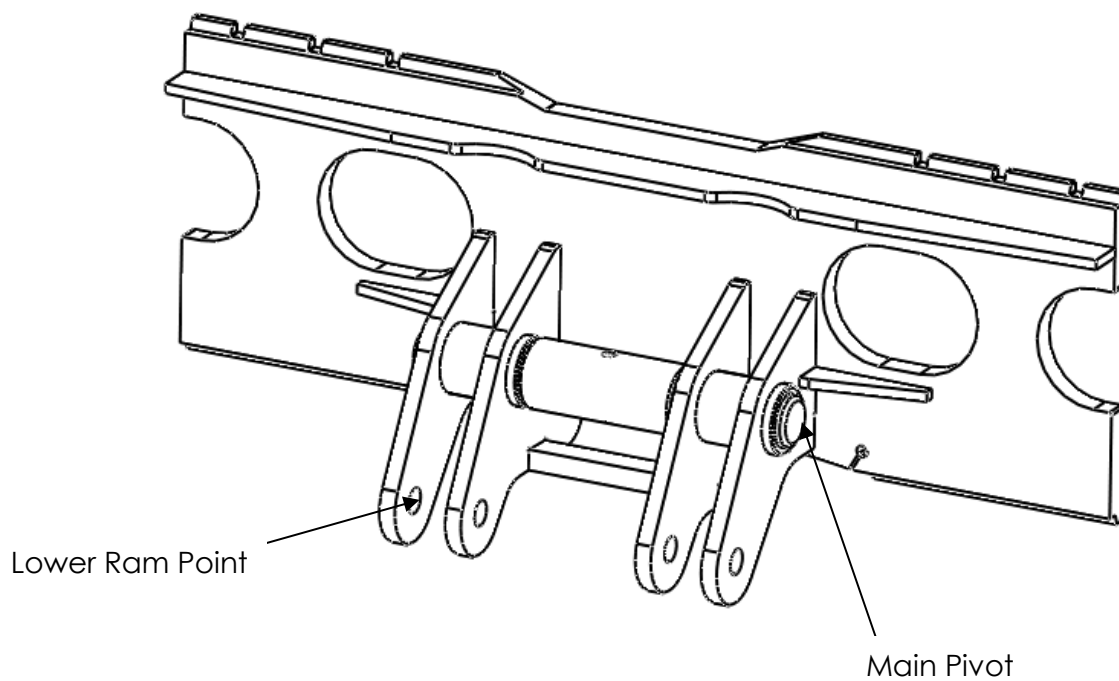
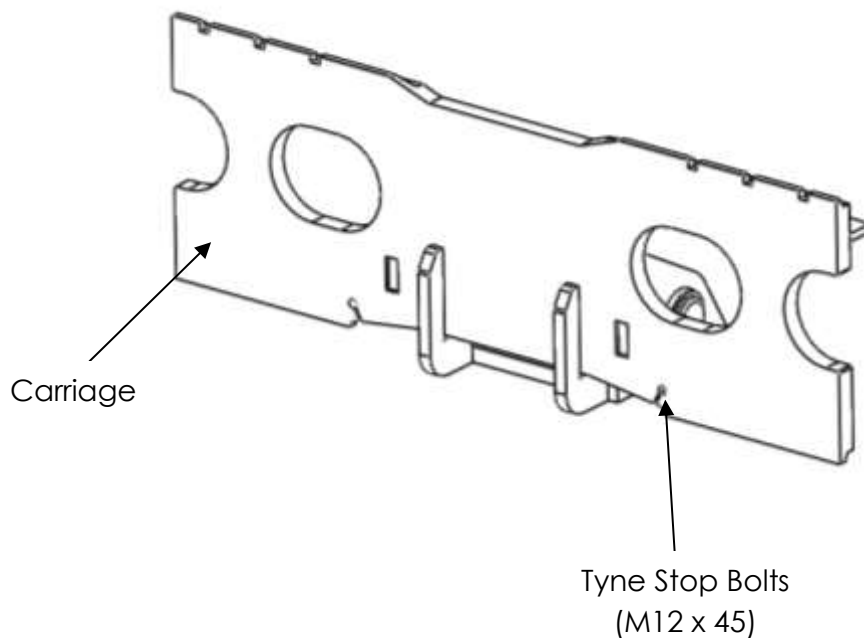

Main shaft assembly



Main Pivot Pin
(60mm Diameter)



80mm Diameter
x 1

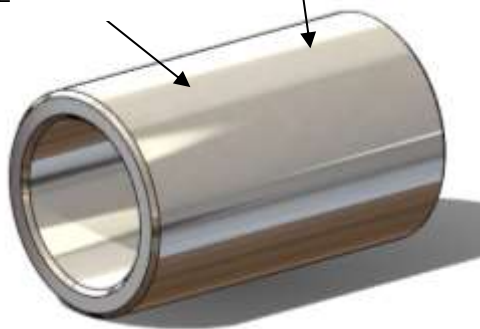

80mm Diameter
x 2

Main Pivot
Bushes

Top arm

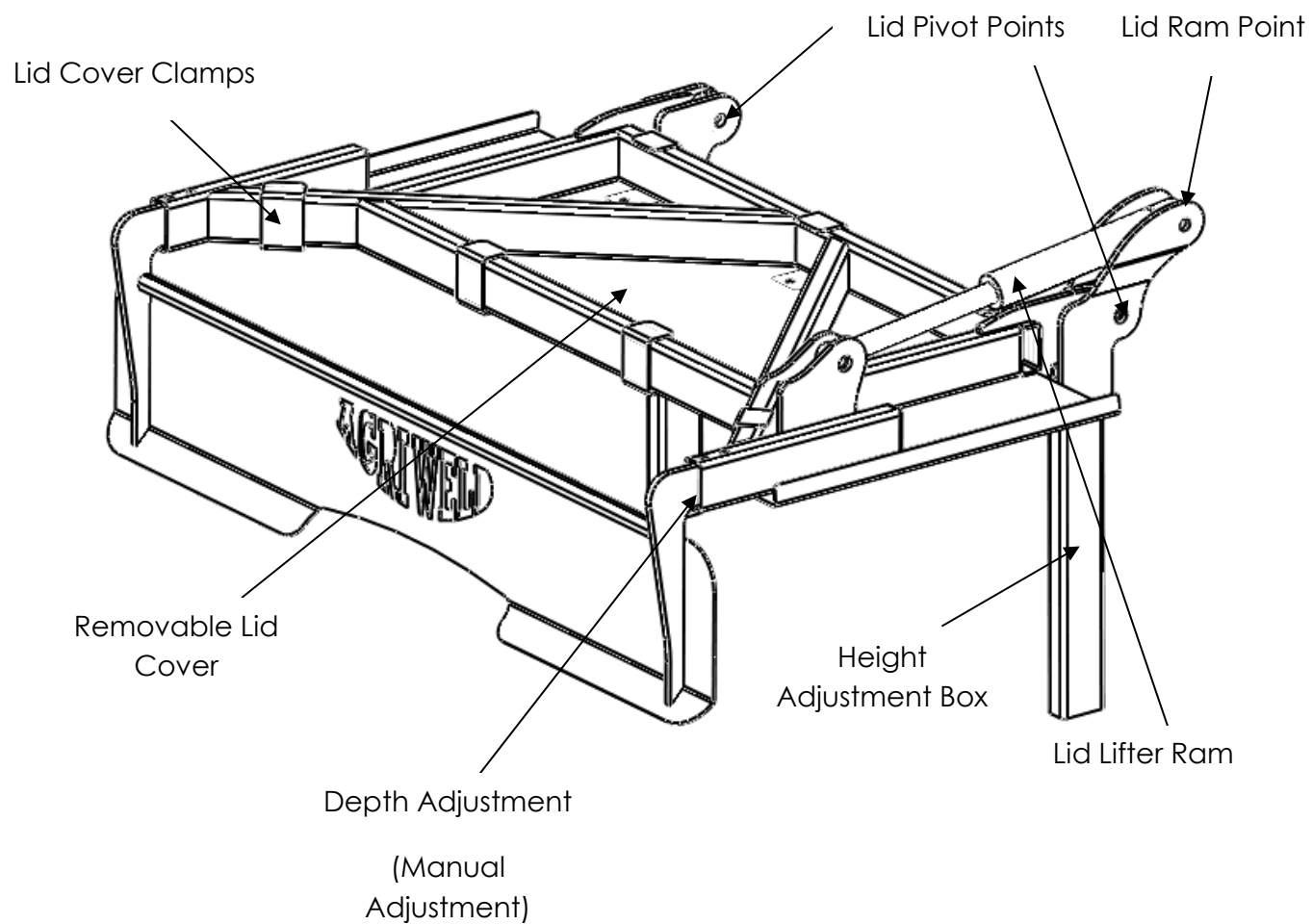

Forklift brackets

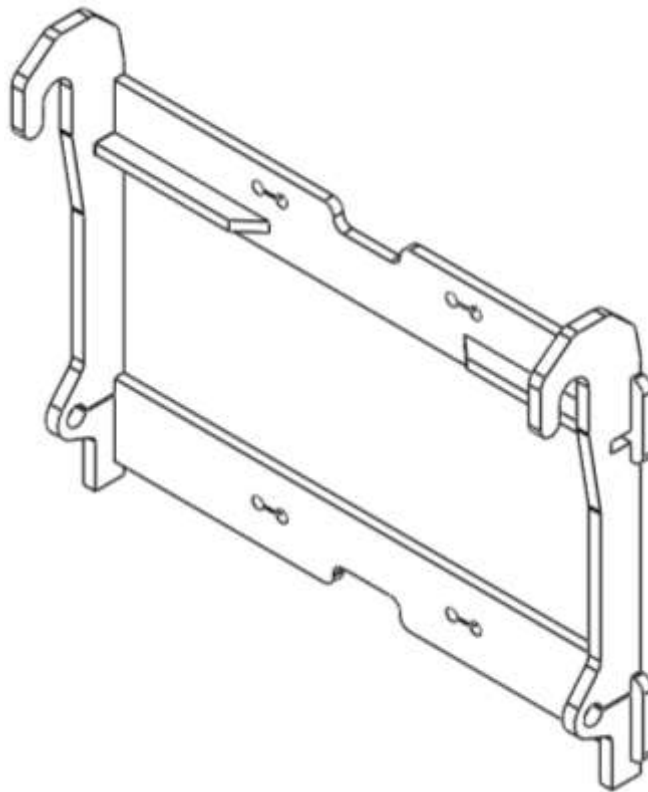

Bolt on brackets for a JCB example.

QUICK-HITCH brackets or CARRIAGE BLOCKS require the following fittings;

8 X M20 X 80mm counter sunk socket head setscrew BZP - high tensile 10.9

8 X M20 high tensile grade 8.8 Nylock nuts

8 X M20 good quality washers (fitted nut side.)

Rams and Pallet Forks



705/3 Main Tipper Ram x 2





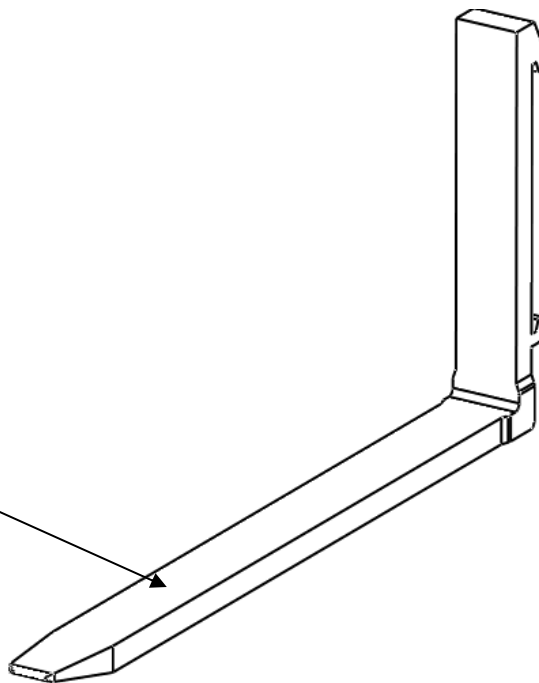

705/4 Lid Lift Ram x 1



Class 2B Pallet Forks x 2

Stickers

Sticker	Part number	Description	Quantity per Machine
	AW_120F_LS	Long 120F Sticker	2
	AW_120_AS (185 mm x 85mm)	Agriweld Sticker	2
	AW_120_GB (85mm x 50mm)	Great Britain Sticker	2
	AW_120_GNS	Grease nipple Sticker	6
	AW_12_OM	Read operator manual Sticker	1

Electric Spiral Cable



KAS1002 Spiral cable 3x0.75 mm²

Technical information

Part number	KAS1002
Unit	Each
Specifications	- Coiled cable suitable for trailer applications
Benefits	- Extremely durable with excellent chemical resistance - Heat and UV resistant
Properties	- Polyurethane cover - Working length: 3m - Complies with ADR regulations
Voltage	12/24 V
Length	3 m
Cable thickness (mm²)	3x0.75 mm ²



Attach to steel plate behind top grab

Operation of the 120F top grab is via this 12V spiral cable (suzy line). It is not provided with the 120F as a standard issue component and is subject to change without prior notice.

Warranty

Your Agriweld 120F is covered for a period of 24 months from the date of despatch (which is recorded on our files) against faulty components and/or bad workmanship.

Our welders are coded to BS EN 287-1 and our welding procedures are approved in accordance with: BS EN ISO 15614-1 to manufacture your equipment and all products are checked for quality prior to despatch/collection.

We cannot be responsible for claims arising from ignorance, occurrences outside our control, such as accidents, and malicious damage.

Damage occurred during transit must be reported on signing for the item from the haulier to enable us to make a claim for damages caused during transport.

WARRANTY CLAIMS FOR DAMAGE DURING TRANSIT

Damage occurred during transit via an external haulier must be reported immediately upon unloading and signing for the item. The limit of our liability to undertake repairs to products damaged during transit is dependent on signing for any damaged product upon delivery as "DAMAGED".



CE DECLARATION OF CONFORMITY

The equipment which accompanies this declaration is in conformity with EU Directive(s):-

2006/42/EC Machinery Directive

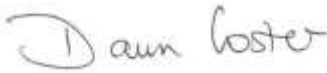
Manufacturer Name:	Agriweld Ltd
Manufacturer Address:	Main Street Garton-on-the-Wolds Driffield East Yorkshire YO25 3ET
Product:	120F Box Rotator
Product Options:	All
Individual Serial Number:	
Product Description:	AGRIWELD 120F Box Rotator
Date of Last Load Test Report:	N/A
Supplementary Information:	
Authorised Signatory on Behalf of Manufacturer:	
Name of Signatory:	Dawn Foster
Position in Company:	Director
Date of Issue:	