

AGRI WELD

Operator Manual

Basic Quickshift

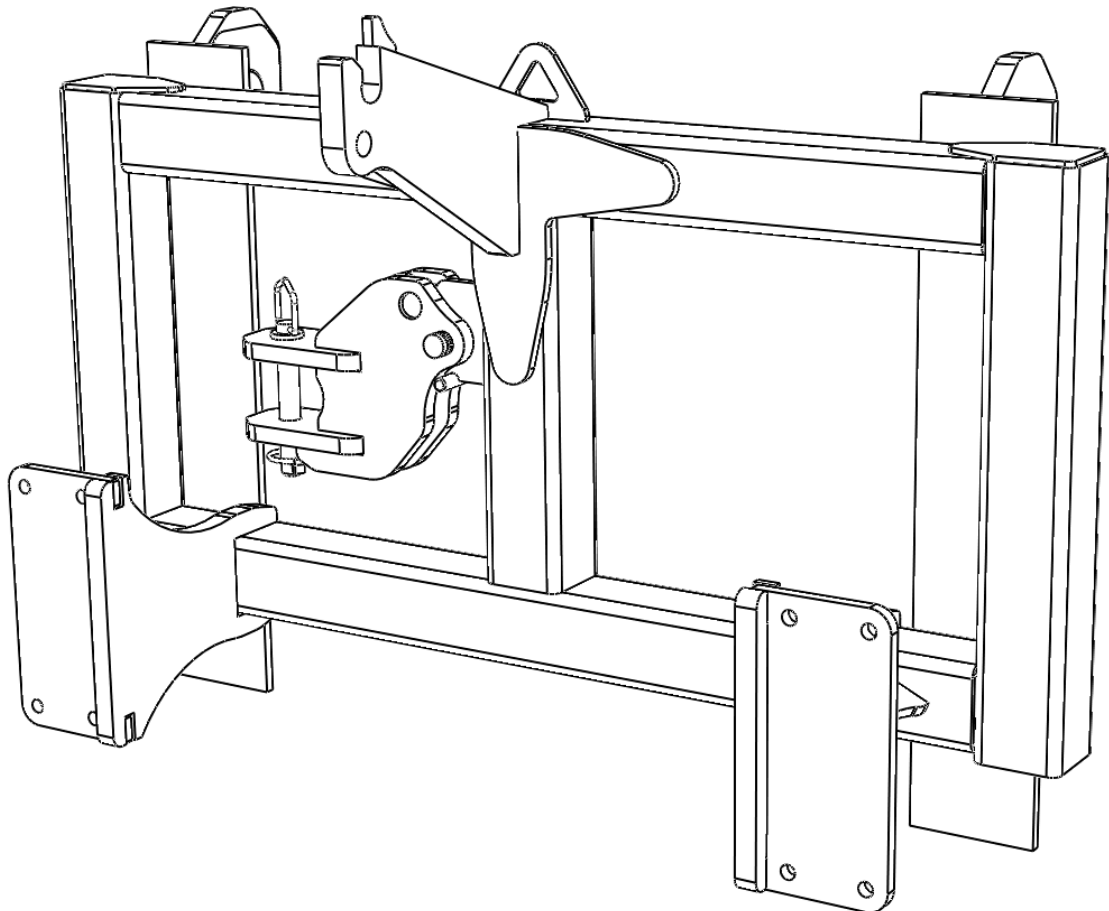

AGRI WELD

www.agriweld.co.uk

The Workshops
Main Street
Garton-on-the-Wolds
Drifffield, YO25 3ET
Tel: 01377 259140
Email: sales@agriweld.co.uk

CONTENTS

Page 3	Assembly
Page 4	Weights, Capacities, Parts List & Machine technical specification
Page 5	Clevis
Page 6	Fitting Towing Clevis
Page 7	Summary, Moving 3 Point Linkage & Moving Trailed Equipment
Page 8	Connecting to forklift loader
Page 9	Capacity & General Safety
Page 10	Qualifications and Training
Page 11	Further Safety and Special Safety Instructions
Page 12	Storage Safety & Important Maintenance
Page 13	Warranty
Page 14	Stickers
Page 15	CE Declaration of Conformity

ASSEMBLY

Brackets (Example)

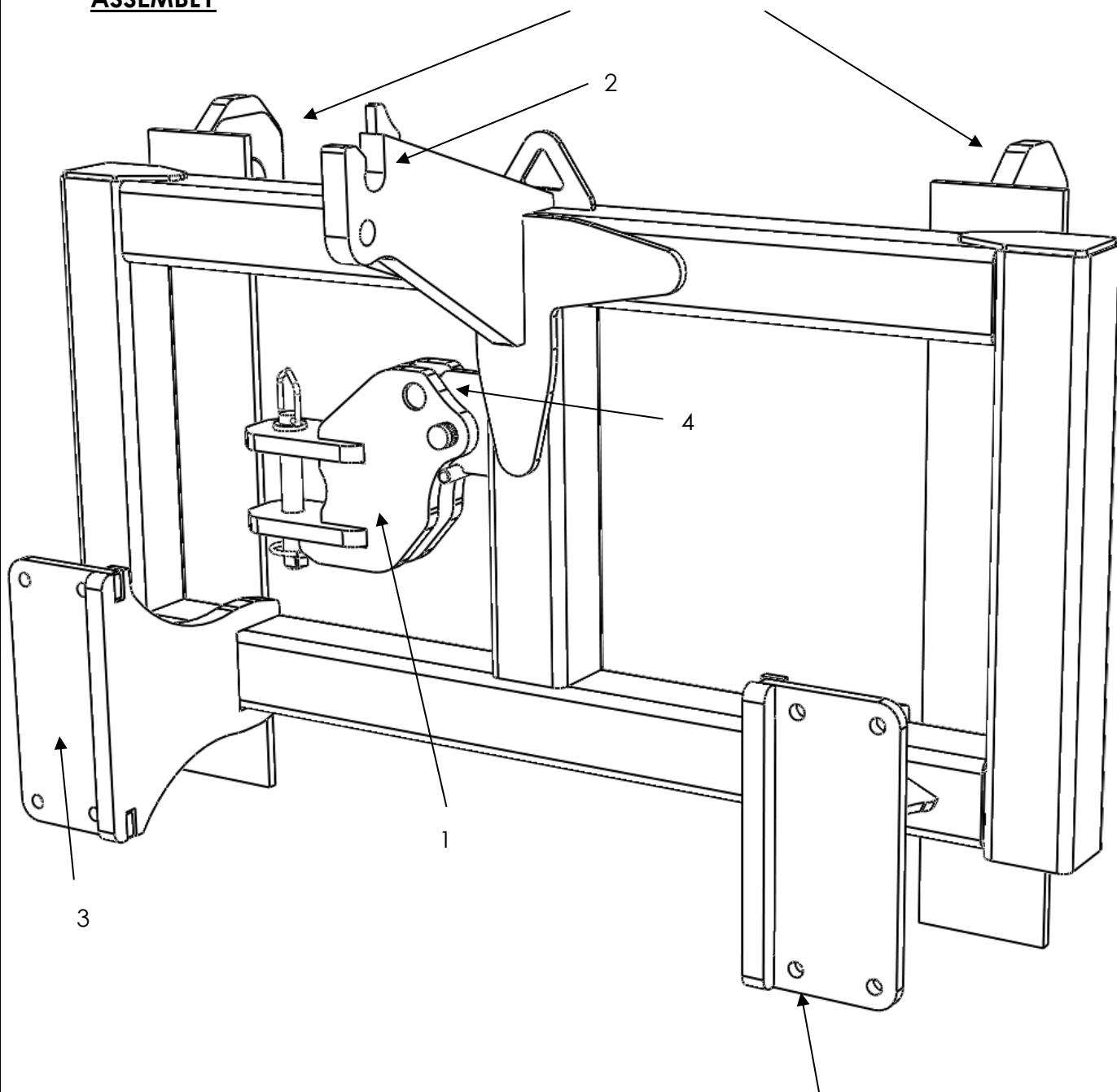

Holes for rubber pads
(optional)

WEIGHTS AND CAPACITIES

Unit Weight	Maximum Capacity
195 KG	5000 KG

Machine technical specification

Weight:	195kgs
LLC:	367mm
Capacity @ LC:	5 Tonnes (or max capacity of forklift/loader if lower than this)
Centre of gravity:	70mm

MAIN FRAME PARTS LIST

Item Number	Part Number	Description	Quantity per Machine
1	SQS_Clev_Main	Towing Clevis	1
2	SQS_3002	Lifting Hook	1
3	SQS_1501	Stabiliser Plate	1
4	SQS_1204	Towing Clevis storage point	1

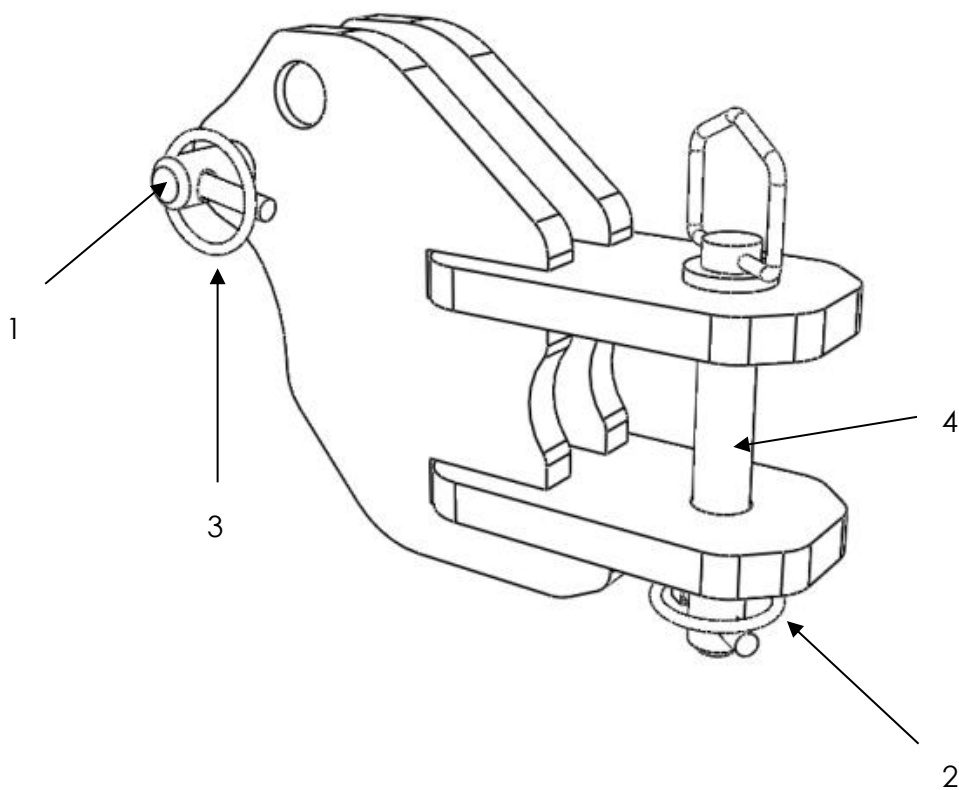
CLEVIS

Item Number	Part Number	Description	Quantity per Machine
1	Z325095KR	Towing Clevis Securing Pin	1
2	LP6Z	Linch Pin	1
3	LP11Z	Linch Pin	1
4	1" Drawbar Pin	Z525157KR	1

Fitting Towing Clevis

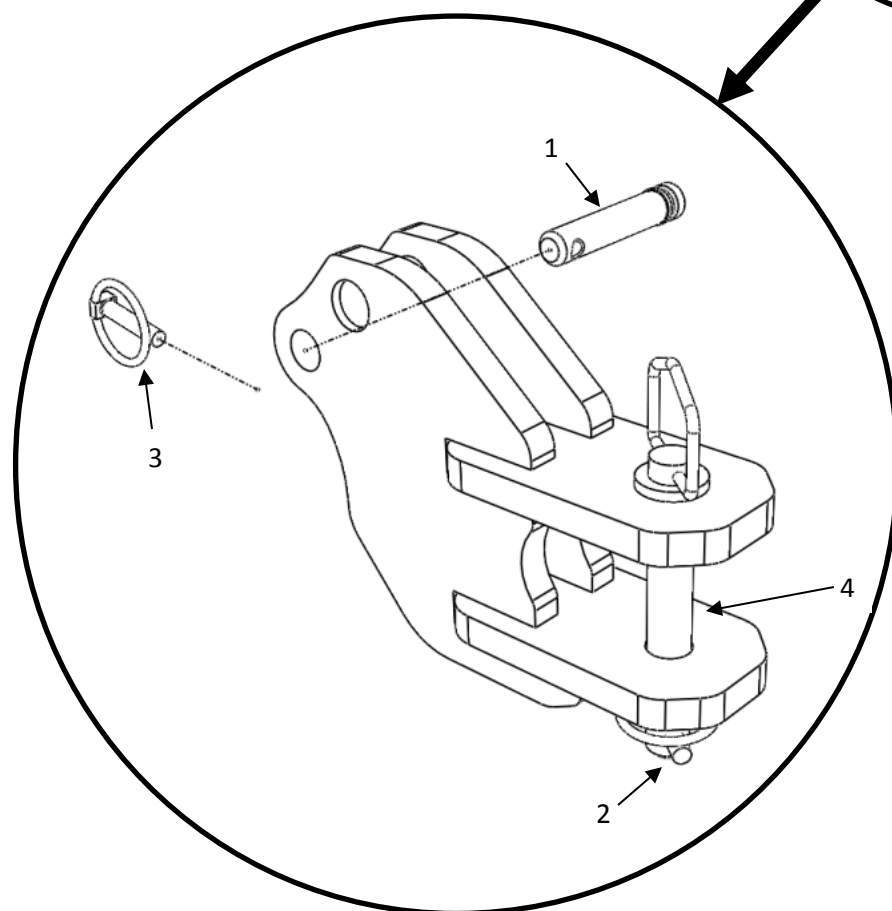
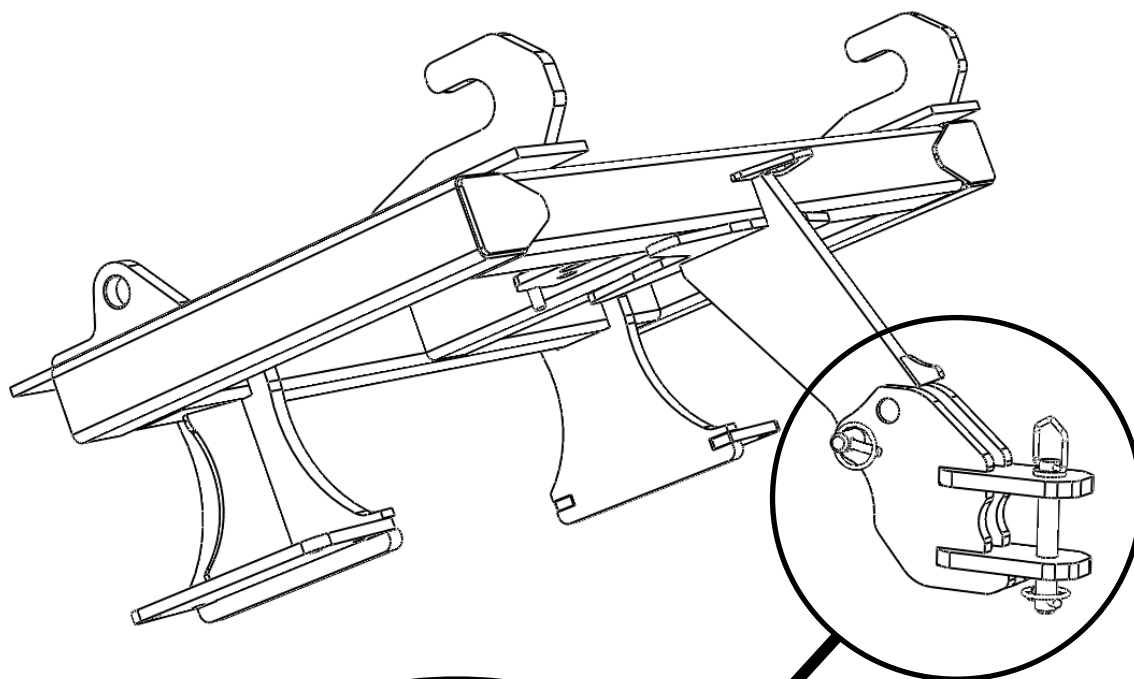

Remove towing clevis from storage point on main frame by removing securing pin (1). Fit to top hook as shown above. Line up hole on towing clevis with hole on lifting hook, replace main securing pin (1), ensure this is secured with the Linch pin (3) Remove and refit Drawbar Pin (4) and Linch pin (2) to attach and detach trailed Equipment.

SUMMARY

The Agriweld BASIC QUICKSHIFT is designed primarily for the safe and efficient movement of all 3 point linkage and trailed equipment.

The QUICKSHIFT forklift/loader attachment consists of a main lifting hook (which locates into the equipment's top link point), left and right lower stabilising plates (which locate into the equipment's lower link points) a main frame and relevant bracketing to fit your forklift or loader.

MOVING 3-POINT LINKAGE EQUIPMENT

The top hook is the main lifting or load bearing component. It locates in to the top link point of the equipment to be moved. The lower stabilising plates lock into the equipment's lower link points and prevent sideways movement whilst the equipment is being lifted and moved.

MOVING TRAILED EQUIPMENT

The QUICKSHIFT carries its own "Clevis" style drawbar attachment on the frame which can be used to move trailed equipment as required. The standard issue drawbar clevis is stored on the QUICKSHIFT frame by use of a pin and is attached to the main lifting hook with the same pin for use.

CONNECTING TO YOUR FORKLIFT LOADER

Please note that this is generalised information and connection may vary depending the type of headstock/brackets fitted. Operators should use their own judgement and experience when hitching/un-hitching the Quickshift and its attachments. Only personnel with the appropriate forklift/loader licence are authorised to use this machine. Statutory minimum age limits must be observed and reliable personnel only should perform maintenance/work on this machine. Persons undergoing training or instruction or taking part in a general training course should only use this machine under direct supervision of an experienced* or trained person. Experienced persons are classed as those individuals who have been trained, know current knowledge and skills or have participated in the use of this type of activity and equipment for several years.

Connection to handler via Quick-hitch bracketing

Tilt loader headstock slightly forwards and drive in slowly to locate loaders top mounting point into Quickshift corresponding top mounting point carefully. Crowd loader headstock back slightly to align lower Quickshift mounting point with the corresponding bracket on the loader headstock and secure with the relevant locking pins.

Carriage blocks/rails (Class 2, 3 or 4)

Tilt forklift carriage rails slightly forward locate top rail into corresponding top Quickshift carriage rail bracket. Crowd back slightly to locate lower carriage rail. Position lower carriage rails/blocks into operating position and secure with the relevant locking pins/bolts.

***Experienced persons are classed as those individuals who have been trained, know current knowledge and skills or are participated in the use of the type of activity and equipment for several years.**

CAPACITY – IMPORTANT INFORMATION

The QUICKSHIFT has been load tested and certified with a safe working load (SWL) of

5 Tonnes*

***When fitted to any forklift or loader with a lift capacity less than 5 tonnes reduces the safe working load (SWL) of the QUICKSHIFT to that of the forklift/loader's capacity.**

For example fitted to a 3 – tonne forklift, the QUICKSHIFT capacity is also reduced to 3 - tonnes.

Warranty claims arising from misuse and overload will not be covered.

GENERAL SAFETY

This manual must be provided to all persons concerned who will be involved with the setting up, operation, maintenance and use of the forklift/loader and QUICKSHIFT. It must be available at all times.

If important safety instructions are not complied with, it can lead to the risk of injury to yourself and others as well as damage to property and the environment.

NON COMPLIANCE WITH SAFETY INSTRUCTIONS CAN LEAD TO WARRANTY CLAIMS BECOMING INVALID.

QUALIFICATIONS AND TRAINING

Only personnel with the appropriate forklift/loader licence are authorised to use this machine.

Statutory minimum age limits must be observed and reliable personnel only should perform maintenance/work on this machine.

Persons undergoing training or instruction or taking part in a general training course should only use this machine under direct supervision of an experienced* and trained person. *See page 8 for definition.

The use of spare parts, accessories and ancillary equipment not supplied or approved by Agriweld, could have detrimental effects to the construction or functions of the QUICKSHIFT. Agriweld shall not be responsible for any damage caused by the use of spare parts or accessories and ancillary equipment not supplied or approved by Agriweld.

The operator must be aware of their responsibilities with regard to observing traffic regulations. The operator must have the authority to refuse instructions issued by third parties which contravene safety.

The operator should only operate what he/she is trained and experienced to do. If you are not confident, assistance should be sought from a suitably qualified person before using the Quickshift and its attachments. Untrained and non-confident operators should be supervised by an experienced operator until it is deemed them safe to use on their own.

The driving characteristics of the forklift/loader are influenced and altered by the attachment of mounted machines and it is important to ensure adequate steering and braking ability as required.

Any conversions or modifications to the machine may only be carried out after prior consultation and written confirmation from Agriweld.

PLEASE NOTE:

All forklifts are subject to L.O.L.E.R inspection / report by reputable engineers and records kept and maintained.



FURTHER SAFETY

Any warning signs/instructions on the machine provide important information and must be observed.

Ensure that you are familiar with the equipment, controls and functions of the forklift or loader and QUICKSHIFT before starting work.

Check round the machine for any noticeable damage, or missing parts before starting work.

It is advisable that the operator wears close fitting clothing to avoid the risk of snagging and trapping.

Ensure that you watch out for wandering individuals (particularly children!).

Remember to take into account the size of any attachments being moved and be aware of the sideways forces acting on the machine when turning and negotiating corners. Always ensure adequate all round visibility.

SPECIAL SAFETY INSTRUCTIONS

Take extra care when hitching up or un-hitching the QUICKSHIFT to/from the forklift or loader. Be aware of what is under the QUICKSHIFT and its load (such as your feet) before dropping off.

Ensure that the forklift or loaders hydraulic system is in full working order.

Never allow any person to stand between the forklift or loader and the QUICKSHIFT during connection or at any time unless the forklift or loader is secured against rolling away by use of a parking brake and/or wheel chocks.

It is forbidden to allow any persons to ride or sit on the QUICKSHIFT and its load at any time. Observers should maintain a safe distance when machine is in use.

When performing any adjustments to the machine the forklift or loader's engine must be switched off to prevent the hydraulics from operating.

NEVER walk or work under a suspended load. Always take measures to support the machine and its load to prevent crushing and/or death. Do not rely on the forklift/loader and QUICKSHIFT alone if you are working under a suspended load. Always use supports for example trestles or a frame capable of taking the load.

STORAGE AND SAFETY WHEN NOT IN USE

Always detach any attachments from the Quickshift when you have finishing using them.

The Quickshift will stand on its own when not mounted or in use, unless forced over by external sources. We advise the Quickshift and its attachments be stored away in an area clear from obstruction without causing hazard to other vehicles, damage to property or injury to individuals and by ensuring that the storage area is easily accessible for next use.

If you need to keep the Quickshift mounted to the forklift/loader in between use, it is important to ensure the Quickshift is lowered to ground level, the vehicle has the hand brake/equivalent secured, the loader engine is turned off and vehicle is locked.

IMPORTANT MAINTENANCE

It is important to check the main lifting hook, stabilising plates, drawbar clevis and pins for wear and ensure that none show significant signs of wear or damage.

Before use, always check round the QUICKSHIFT to ensure no damage has occurred and that the machine appears safe to use.

Keep the QUICKSHIFT clean at all times to ensure easy inspection.

Ensure that the forklift or loader is in full working order and that the QUICKSHIFT is attached to the forklift or loader correctly before starting work.

Never use the Quickshift and any attachments if any parts/pins are missing.

Routine maintenance and safety checks of the Quickshift does not require the operator to climb/stand on the machine at any time.

Do not overload the forklift and Quickshift, refer to capacity on page 10 for details. Only use the Quickshift for its intended purpose.

The Quickshift is subject to L.O.L.E.R inspections annually.

WARRANTY

Your Agriweld BASIC QUICKSHIFT is covered for a period of 12 months from the date of dispatch (which is recorded on our files) against faulty components and/or bad workmanship.

Our welders are coded to BS EN 287-1 and our welding procedures are approved in accordance with: BS EN ISO 15614-1 to manufacture your equipment and all products are checked for quality prior to delivery/collection.

We cannot be responsible for claims arising from ignorance, occurrences outside our control, such as accidents, and malicious damage.

Damage occurred during transit must be reported on signing for the item from the haulier to enable us to make a claim for damages caused during transport.



WARRANTY CLAIMS FOR DAMAGE DURING TRANSIT

Damage occurred during transit via an external haulier must be reported immediately upon unloading and signing for the item. The limit of our liability to undertake repairs to products damaged during transit is dependent on signing for any damaged product upon delivery as "DAMAGED".

OPTIONAL ATTACHMENTS

The Basic Quickshift does not have the facility for further attachments.

STICKERS

Sticker	Part Number	Description	Quantity per Machine
	AW_QS_LS (460mm x 90mm)	Quickshift sticker	2
	AW_QS_AS (185 mm x 85mm)	Agriweld sticker	2
	AW_QS_GB (85mm x 50mm)	Great Britain sticker	2



CE DECLARATION OF CONFORMITY

The equipment which accompanies this declaration is in conformity with EU Directive(s):-

2006/42/EC Machinery Directive

Manufacturer Name:	Agriweld Ltd
Manufacturer Address:	Main Street Garton-on-the-Wolds Driffield East Yorkshire YO25 3ET
Product:	Basic Quickshift Lifting Frame
Product Options:	All
Individual Serial Number:	
Product Description:	An attachment specifically for use on forklifts/loaders with a maximum lift capacity of 5000kg for the lifting and moving of 3 point linkage and trailed equipment.
Date of Last Load Test Report:	13/04/2018
Supplementary Information:	This equipment is subject to LOLER inspection (Lifting Operations and Lifting Equipment Regulations 1998) within 12 months of putting into service.
Authorised Signatory on Behalf of Manufacturer:	
Name of Signatory:	Dawn Foster
Position in Company:	Director
Date of Issue:	