

AGRIWELD

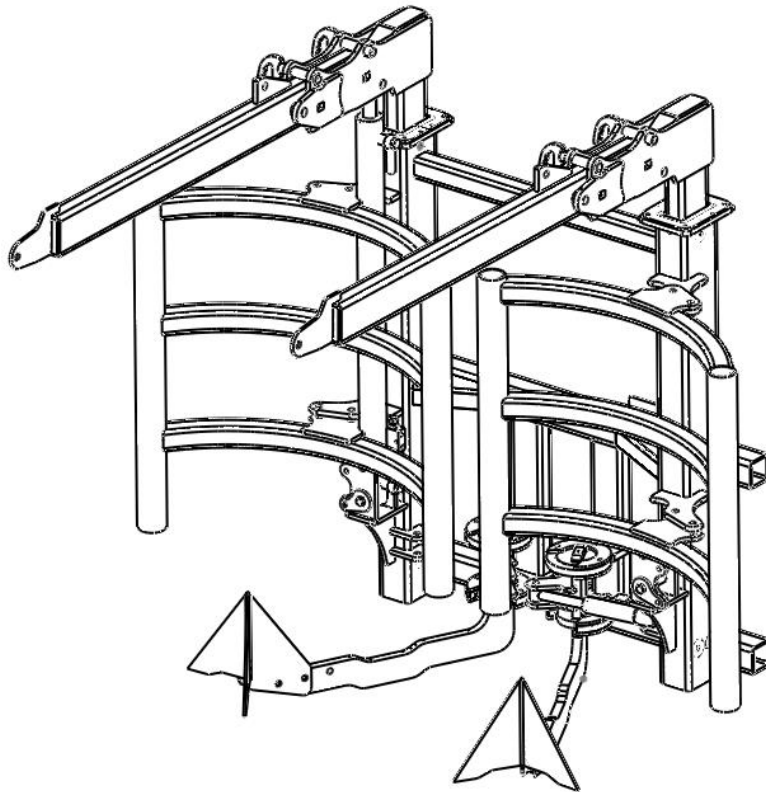

OPERATOR MANUAL

ABC Agriweld Bag Cutter



The Workshops
Main Street
Garton-on-the-Wolds
Driffield, YO25 3ET
Tel: 01377 259140
Fax: 01377 259141

Email: sales@agriweld.co.uk



www.agriweld.co.uk

Contents Page

Page 3	Summary and General Safety
Page 3-4	Qualifications, Training, Further Safety & Special Safety Instructions
Page 5-6	Operation
Page 7	Full Assembly
Page 8	Top arm assembly
Page 9	Bag cutting blade assembly
Page 10	Parts list
Page 11	Hydraulic Diagram
Page 12	Stickers
Page 13	Warranty
Page 14	CE Declaration of Conformity

Summary & Capacities

The Agriweld Bag Cutter (ABC) is a hydraulically operated, implement used for carrying and cutting 4 x 600kg or 2 x 1000kg fertiliser/seed bags. It is designed to fit any forklift/loader with a minimum capacity of 3000kgs for a twin model or 2000kgs for a single model, by use of the relevant bracketing to suit your forklift/loader and as provided with the implement. It is designed and manufactured by Agriweld in Great Britain.

CAPACITY

Please note the capacity of your ABC as per correct configuration below;

CONFIGURATION:	Twin ABC
SAFE WORKING LOAD (SWL):	2500Kgs
WEIGHT:	Approx. 580Kgs

General Safety

This manual must be provided to all persons concerned who will be involved with the setting up, operation, maintenance and use of the forklift/loader and the bag lift and must be available at all times.

If important safety instructions are not complied with, it can lead to the risk of injury to yourself and others as well as damage to property and the environment.

PLEASE NOTE

NON COMPLIANCE WITH SAFETY INSTRUCTIONS CAN LEAD TO WARRANTY CLAIMS BECOMING INVALID.

Qualifications and Training

Only personnel with the appropriate forklift licence is authorised to use this machine.

Statutory minimum age limits must be observed and reliable personnel only should perform maintenance work on this implement.

Persons undergoing training or instruction or taking part in a general training course should only use this machine under direct supervision of an experienced and trained person.

The use of spare parts, accessories and ancillary equipment not supplied or approved by Agriweld could have detrimental effects to the construction or functions of the Agriweld Bag Lift. Agriweld shall not be responsible for any damage caused by the use of spare parts or accessories and ancillary equipment not supplied or approved by Agriweld.

The operator must be aware of their responsibilities with regard to observing traffic regulations. The operator must have the authority to refuse instructions issued by third parties which contravene safety. Any conversions or modifications to the machine may only be carried out after prior consultation and written confirmation from Agriweld.

Further Safety

Any warning signs/instructions on the implement provide important information and must be observed.

Ensure that you are familiar with the equipment, forklift controls and functions before starting work.

Check round the implement for any noticeable damage, or missing parts before starting work.

It is advisable that the operator wears close fitting clothing to avoid the risk of snagging and trapping.

Ensure that you watch out for wandering individuals (particularly children!).

Always match your speed to the conditions and speed limits imposed.

Remember to take into account the size of any attachments to the forklift/loader you may have and be aware of the sideways forces acting on the machine when turning and negotiating corners. Always ensure adequate all round visibility.

Special Safety Instructions

Take extra care when hitching up or un-hitching the bag lift to/from the forklift/loader. Be aware of what is under the bag lift (such as someone's feet) before dropping it off.

Ensure that the forklift/loaders hydraulic system is in full working order.

Never allow any person to stand between the forklift/loader and the bag lift during connection or at any time unless the forklift/loader is secured against rolling away by use of a parking brake and/or wheel chocks.

It is forbidden to allow any persons to ride or sit on the bag lift at any time. Observers

should maintain a safe distance when machine is in use.

When performing any adjustments to the bag lift the forklift/loader engine must be switched off to prevent the hydraulics from operating.

Safety First

Everyone is responsible for Health and Safety! Please operate your forklift or loader with this implement attached in a sensible and safe manner. Be aware of the safety of others at all times.

Operation

1. Ensure that the bag cutter is attached to the forklift/loader correctly and any locking pins are located securely.
2. Ensure that the forklift/loaders hydraulic system is in full working order prior to use.
3. Allow time on first use to get used to the forklift/loader with the implement attached.
4. Manoeuvre around at a very slow pace and ensure that there are no spectators within close proximity or overhead obstructions.
5. SAFETY FIRST: We are all responsible for Health and Safety so please use this implement responsibly. Please follow the operation instructions below.

General Operation

Once mounted to the forklift/loader and you are ready to proceed the following step by step instructions will help to guide you through use.

1. Remove the rubber edge trim (supplied by Agriweld) off the bag cutter blades before use and keep safe as these will need to be re-applied after use/for storage.
2. Pick up the bags ensuring that the bag loops are located fully up to the "stop" positioned on top of the lift arms.
3. Raise the bags off the floor or trailer using the forklift and tilt back slightly to keep the load against the support cradle.
4. We recommend that you drive to the spreader or drill with the bag lift arms fully closed at this point and NOT RAISED.
5. When at the desired location, **YOU MUST CHECK ABOVE FOR ANY OVERHEAD CABLES OR OBSTRUCTIONS** and move to a safer location if required. When it is deemed safe to proceed, lift the bag cutter arms fully up using the hydraulics. Once in this position, the cutters will automatically swing forward into the cutting position.
6. Lower the bags using the hydraulics onto the cutters. There is no need to bury the cutter right up into the bag. When the bag is pierced sufficiently for the

product to flow quickly, lift the bag/s up off the cutter/s and let the bag fully empty.

7. **If loaded with 4 x 600kg bags, tilt fully back so that the second bag slides down to the “stop” as you did for the first bag and repeat the operation.**
8. When you have emptied the bags, keeping the bag lift arms raised, drive to a safe location, to drop off the empty bags. **BEWARE OF ANY OVERHEAD CABLES & OBSTRUCTIONS whilst manoeuvring around**
9. With the cutters still in their working position, tilt the forklift carriage forwards so that the bags slide off.
10. After you have dropped off the empty bags, tilt the carriage back to return the bag cutter to normal centred position and lower the bag lift arms to their lowest position. The cutters will then retract and the operation is complete.
11. For storage of the ABC when not in use, the arms must be lowered to the maximum position achievable without the cutters retracting as the ABC will not stand upright with the cutters retracted. Please ensure the cutters are faced towards a wall for example to ensure you minimise injury or damage and re-apply the rubber edging on to the cutter blades (provided by Agriweld) when ABC is not in use.

Full Assembly

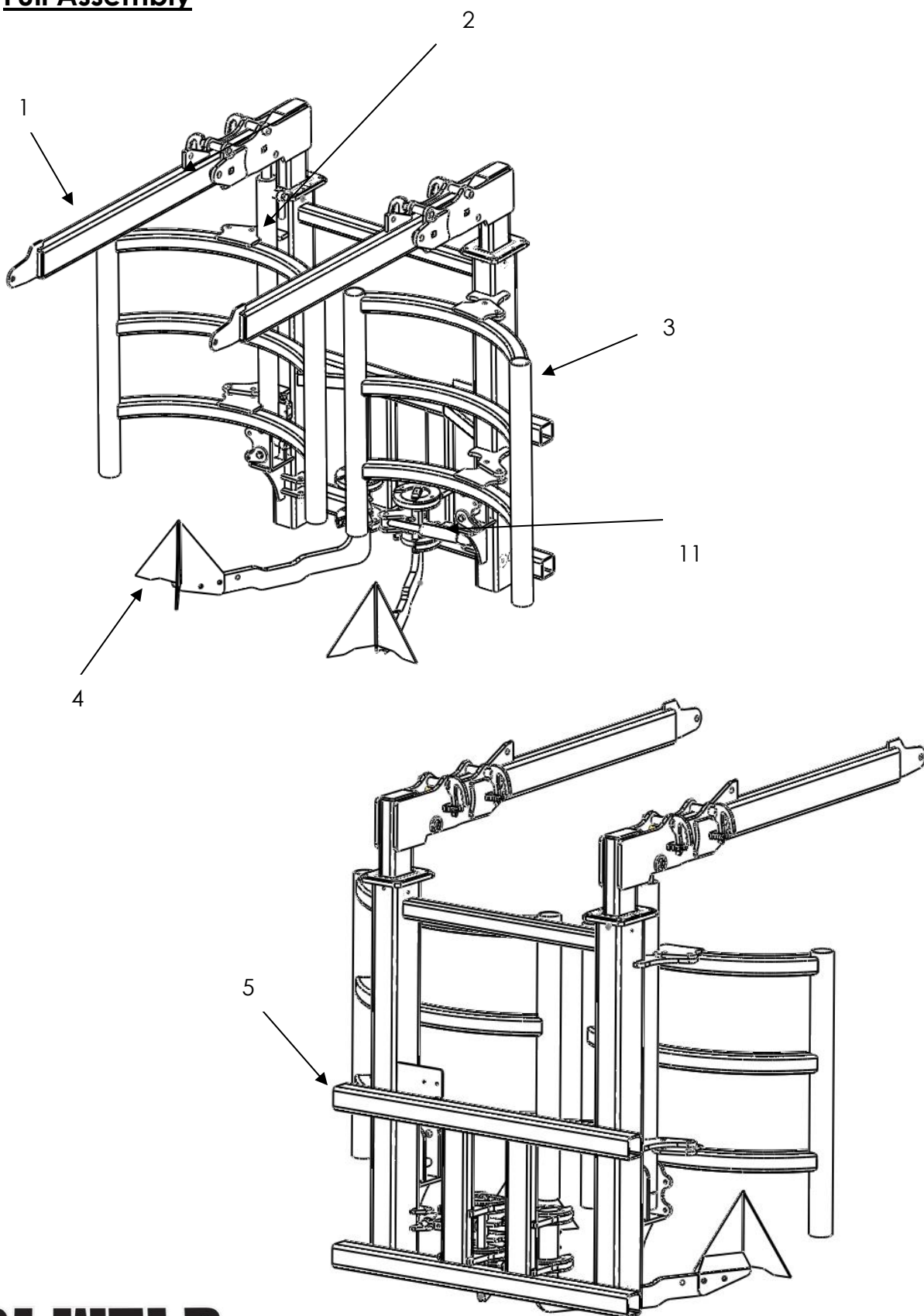

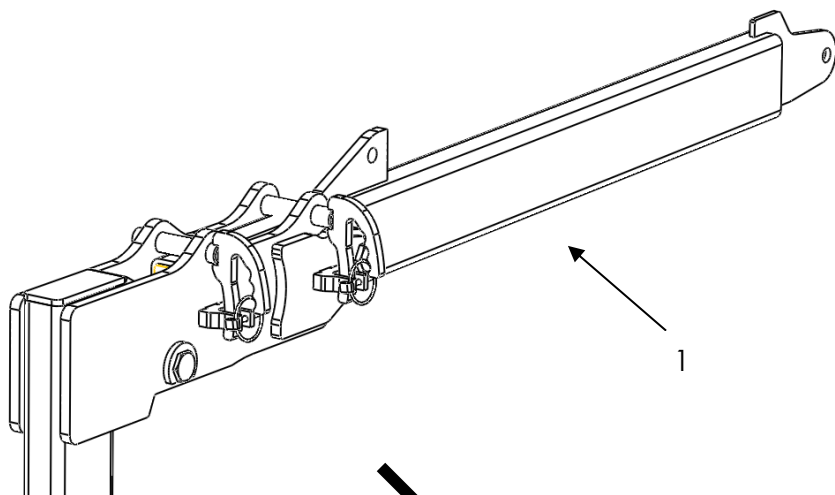

To put arm in transport position, remove lynch pins (7) and pull out the Top arm securing pins (8). This will allow the arm to fold down to the transport position. After this, the lynch pins and main top arm securing pins can be put back.

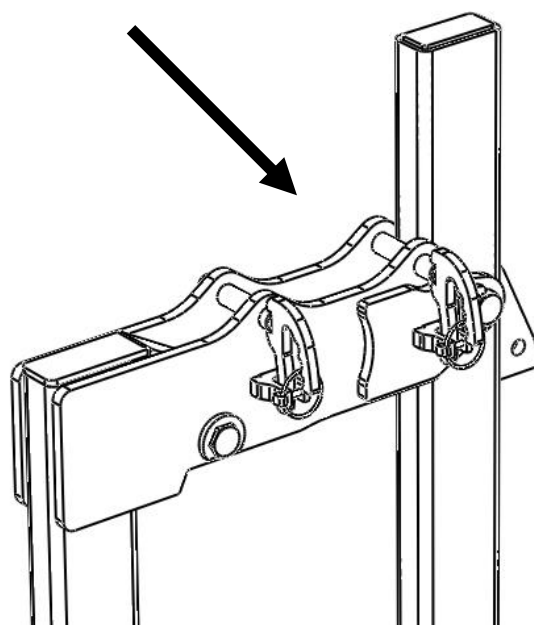
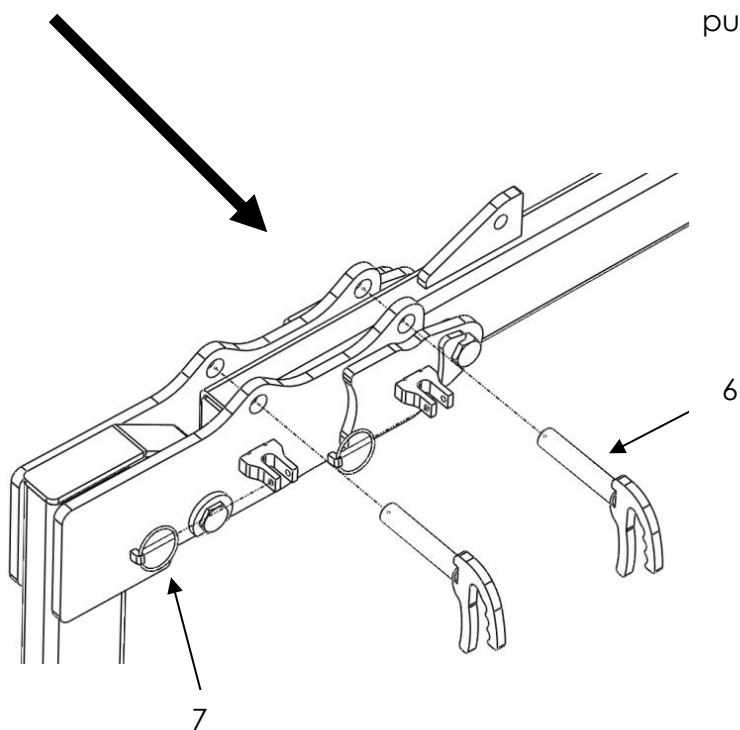

To remove the bag cutting blade, remove the M16 Nuts and bolts.

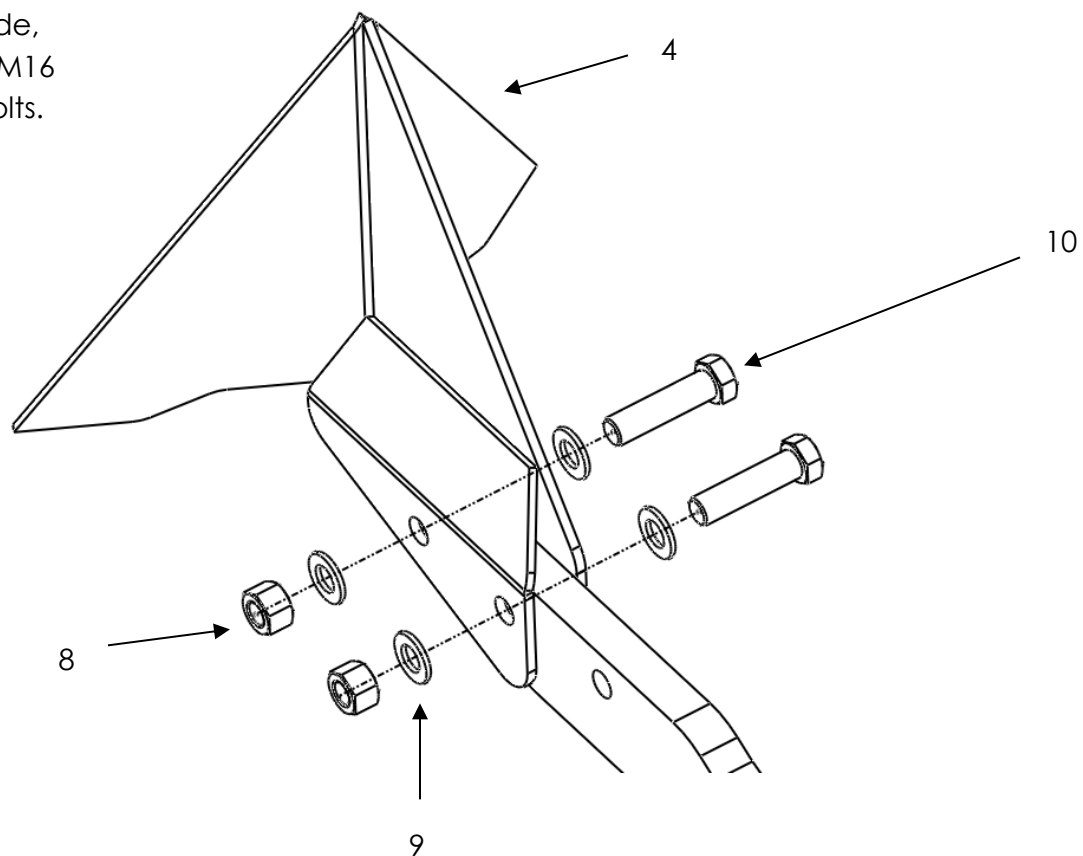

Please note: For safety purposes, Agriweld supplies every machine with rubber edge trim (not shown in above image) to fit over each cutter blade, it is your responsibility to ensure this is removed before use and re-applied after use to minimise the risk of any injury while not in use/in storage.





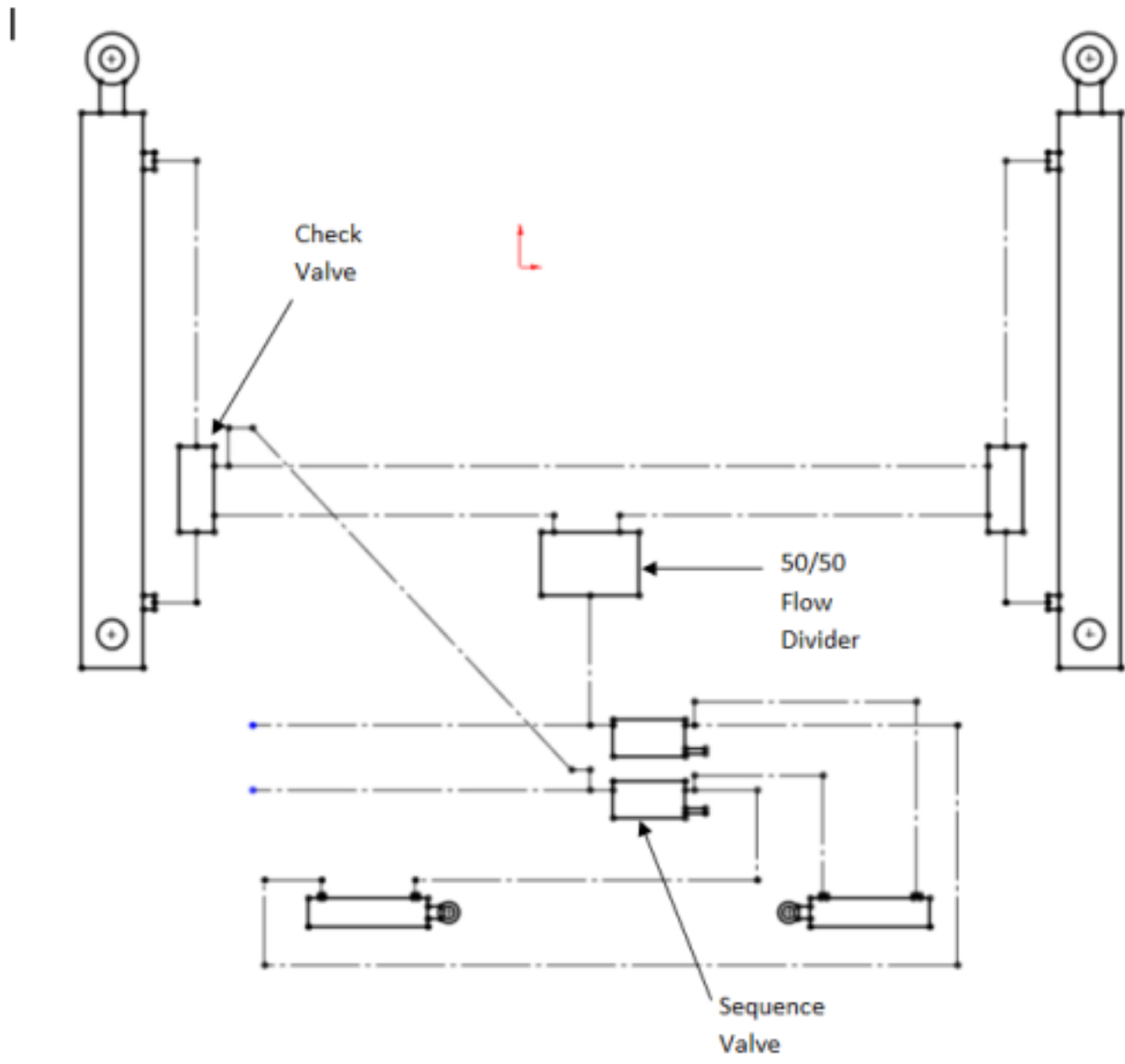

PARTS LIST:

<u>No</u>	<u>Part No</u>	<u>Description</u>	<u>Quantity Per Machine</u>
<u>1</u>	120_60_01	Main top arm	2
<u>2</u>	D30_60_1000_ST_CYL	Lift Rams	2
<u>3</u>	-	Main Frame Guard	2
<u>4</u>	0606_SS	Bag Cutting Blade	2
<u>5</u>	-	Main Frame	1
<u>6</u>	Top_Tube_Pin_01	Top arm securing pin	4
<u>7</u>	LP6Z	Linch Pin	4
<u>8</u>	AW_M16_N	M16 Nut	2
<u>9</u>	AW_M16_W	M16 Washer	4
<u>10</u>	AW_M16X50_B	M16 Bolt	2
<u>11</u>	D20_32_100_CB_CYL	Cutter rams	2

Hydraulic Diagram



Stickers

Sticker	Part number	Description	Quantity per Machine
	AW_BL_AS (185 mm x 85mm)	Agriweld Sticker	1
	AW_MGIB (85mm x 50mm)	Great Britain Sticker	2
	AW_ABC_17	ABC Sticker	2
	AW_180_OM	Read operator manual sticker	1
	AW_ST	Agriweld Stencil Sticker	2
	AW_GN	Grease Nipple Sticker	8
	AW_HT	Hand Trap Warning	2

Warranty

Your Agriweld Bag Cutter is covered for a period of 12 months from the date of delivery (which is recorded on our files) against faulty components and/or bad workmanship.

Our welders are coded to BS EN 287-1 and our welding procedures are approved in accordance with: BS EN ISO 15614-1 to manufacture your equipment and all products are checked for quality prior to delivery/collection.

We cannot be responsible for claims arising from ignorance, occurrences outside our control, such as accidents, and malicious damage.

Damage occurred during transit must be reported on signing for the item from the haulier to enable us to make a claim for damages caused during transport.

WARRANTY CLAIMS FOR DAMAGE DURING TRANSIT

Damage occurred during transit via an external haulier must be reported immediately upon unloading and signing for the item. The limit of our liability to undertake repairs to products damaged during transit is dependent on signing for any damaged product upon delivery as "DAMAGED".

CE DECLARATION OF CONFORMITY

The equipment which accompanies this declaration is in conformity with EU Directive(s):-

2006/42/EC Machinery Directive

Manufacturer Name:	Agriweld Ltd
Manufacturer Address:	Main Street Garton-on-the-Wolds Driffield East Yorkshire YO25 3ET
Product:	ABC Agriweld Bag Cutter
Product Options:	Twin model
Individual Serial Number:	
Product Description:	AGRIWELD Bag Cutter used for carrying/transporting & cutting 4 x 600kg fertiliser/feed bags.
Date of Last Load Test Report:	N/A
Supplementary Information:	
Authorised Signatory on Behalf of Manufacturer:	 
Name of Signatory:	Dawn Foster
Position in Company:	Director
Date of Issue:	

